

HFLUM2-WR

Fixture Integrated Sensor Module

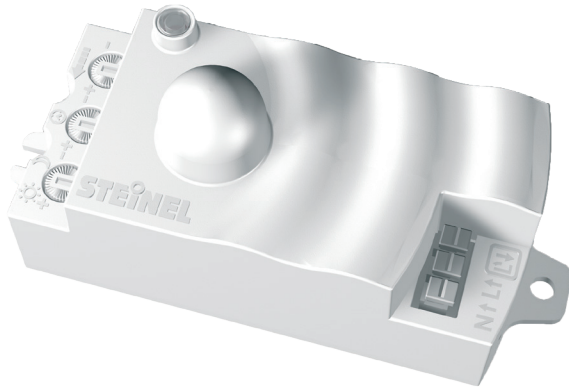

Project Name:
Location:



HFLUM2-WR Specifications

Item No.	65122
Voltage	120/230/277 VAC, 50/60 Hz
Load Rating	0-800 watts @ 120 VAC, 50/60 Hz incandescent, magnetic or electronic ballasts - 1/4 HP 0-1200 watts @ 230/277 VAC, 50/60 Hz magnetic or electronic ballasts 0-650 watts @ 120/230/277 VAC, 50/60 Hz LED
Transmitter Power	1 mW
Power Consumption	< 0.5 W
Time Delay Setting	30 seconds to 30 minutes
Light Level Setting	0.2-200 footcandles 2-2000 lux
HF System	5.8 GHz
Coverage	360° adjustable 3.3 to 26 ft reach (1 to 8 m)
Environment	requires enclosure temperature -4° F - 185° F, -20° C - 85° C
Dimensions (LxWxD)	4.2 x 1.7 x 1.8 in 107 x 42 x 44.5 mm
Warranty	5 years
Certifications	C-UL-US Listed, RoHS Compliant, Contains: FCC ID - W8J-SIR13, IC - 8529A-SIR13

The HFLUM2-WR is a line voltage occupancy sensor module that installs in a fixture, adding energy saving lighting control in each fixture location.

The HFLUM2-WR uses STEINEL's High Frequency (HF) technology to turn lights on and off based on occupancy. It works by emitting high frequency electromagnetic waves (5.8 GHz) into the controlled area. Movement in the area causes a change in the waves' echo, resulting in occupancy detection. The sensor can detect motion through many materials including glass and the lens of a fixture, enabling the sensor to be hidden from view.

Applications

Mounted in either a ceiling or wall lighting fixture, the sensor module is suited to a wide variety of interior spaces including offices, conference rooms and damp or wet locations when mounted inside sealed and gasketed fluorescent IP65 type fixtures.

Key Features:

- 360° coverage; reach is adjustable from 3.3 to 26 ft
- High frequency technology emits 5.8 GHz electromagnetic waves
- Built-in surge protection with auto-reset
- Lamp seasoning feature provides a simple and convenient 4 day burn in as recommended by lamp manufacturers
- Adjustable time delay and light level settings
- Light level feature allows lighting to remain off during daylight, regardless of occupancy (hold off)
- Wiring is streamlined with three terminals

120/230/
277V

Line Voltage

HF
5.8 GHz

High Frequency Technology



360° of Coverage



Fixture Integrated



0.2 - 200 fc

HFLUM2-WR

Fixture Integrated Sensor Module

Controls

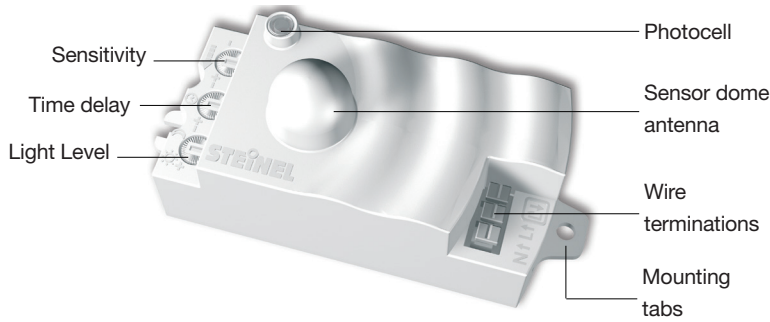

Coverage

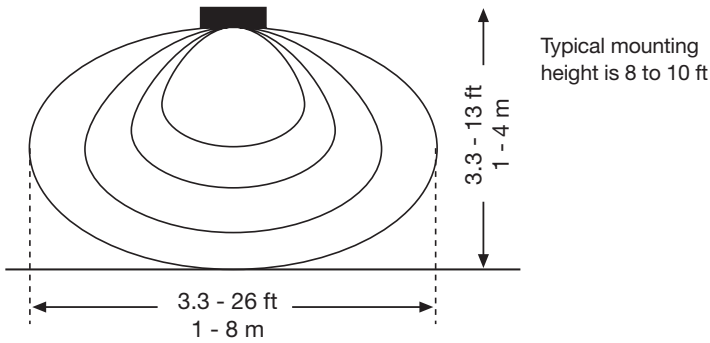

Mounting

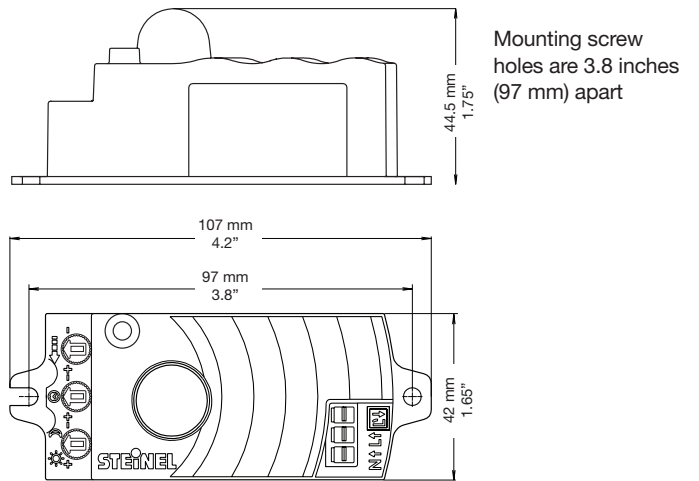

Coverage Adjustments

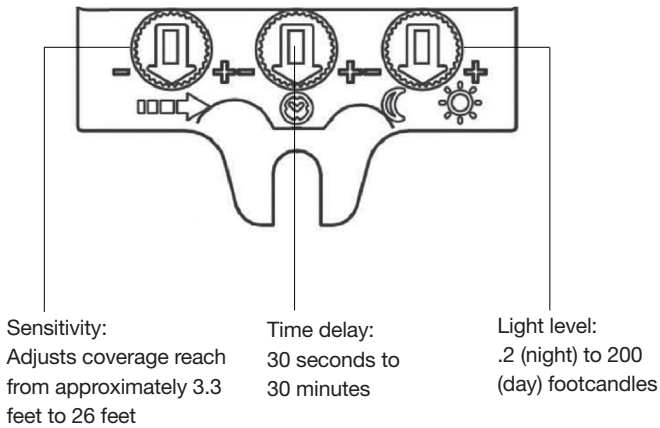

Wiring

