

DT CM COM1-24

Presence Detector



The DT CM COM1-24 Dual Technology Presence Detector utilizes passive infrared and ultrasonic technologies to detect the presence or signature of a person in a space. The logic options for initial “ON” and “Maintained” state of occupancy gives design engineers and installation contractors the choice for proper control of lighting and building automation in difficult applications where detection options are needed in a single device. Lighting loads are controlled in relation to both presence detection and selectable ambient light levels with the integrated force off photocell to maximize energy savings. STEINEL’s world class PIR optics and ultrasonic signal processing provides unparalleled line of sight and volumetric presence detection. Operational choices of auto on or manual on with a momentary or maintained switch input. The convenient “COM-Link” feature enables multiple sensors to link together via the communication link for peer to peer grouping achieving expanded detection zones with convenient control set up functions set at only one primary sensor for the entire group. The available service and user wireless remotes provide simplified commissioning and occupant convenience.

Applications

Typical applications include classrooms, conference rooms, computer rooms, storage rooms, workspaces, open office space with cubicles, general open areas, restrooms, stairwells, storage rooms, executive offices and private offices.

Project Name:

Location:



DT CM COM1-24 Specifications

Item No.	65500 DT CM COM1-24
Accessories	65900 Smart remote 65800 RC 8 programming remote 65320 RC 4 user remote
Voltage	18 - 24 VDC/VAC (32 mA) 50/60 Hz
Load Rating	control output (blue) - 1 A @ 24 VAC/VDC
Sensing Technologies	passive infrared (PIR), single pyro, 11 detection levels, 520 switching zones, ultrasonic 40 kHz
Time Delay Setting	control output 30 sec. - 30 min. pulse mode (approx. 2 sec. 'ON' 8 sec. 'OFF') IQ mode (automatic adjustment to the usage profile)
Light Level Setting	10 - 1000 lux / 1 - 100 fc
Environment	IP20 rated, 0°C to +55°C, 32°F to +131°F
Ultrasonic Detection Zones: (Coverage at 2.5 m / 9 ft)	presence: max. 7 m (130 sq.m.) / min. 20% max. 22 ft (426 sq.ft.) / min. 20% radial: max. 11.5 m (376 sq.m.) / 38 ft (1236 sq.ft.) tangential: max. 8 m (218 sq.m.) / 26 ft (718 sq.ft.)
PIR Detection Zones: (Coverage at 2.5 m / 9 ft)	presence: max. 7 m (134 sq.m.) max. 22 ft (440 sq.ft.) radial: max. 8 m (200 sq.m.) / 26 ft (655 sq.ft.) tangential: max. 25 m (1612 sq.m.) / 82 ft (5290 sq.ft.)
Dimensions	4.72 x 2.76 x 4.21 in, 120 x 70.2 x 107 mm (LxWxD)
Warranty	5 years
Certifications	C-UL-US Listed, RoHS compliant, CA Energy Code compliant

Key Features:

- Low voltage (18-24 VDC/VAC) sensor for use with a power pack or building automation system
- PIR & ultrasonic (40 kHz) presence detection
- Service and user wireless remotes available
- Manual ON mode (MAN) / Automatic mode (AUTO)
- Momentary / Maintained switch option
- 'ON' only / 'ON' & 'OFF' manual switching
- Light level feature turns lights off when sufficient daylight is present
- IQ Mode dynamically adjusts the 'ON' time delay by learning individual room occupancy



DT CM COM1-24

Presence Detector



Wiring

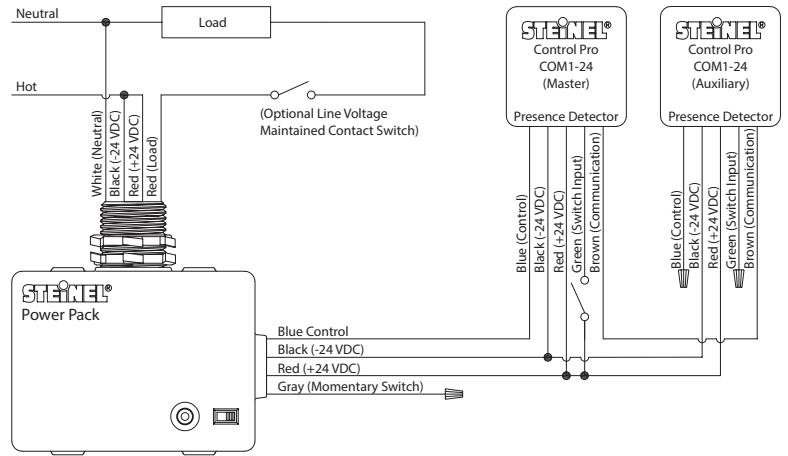
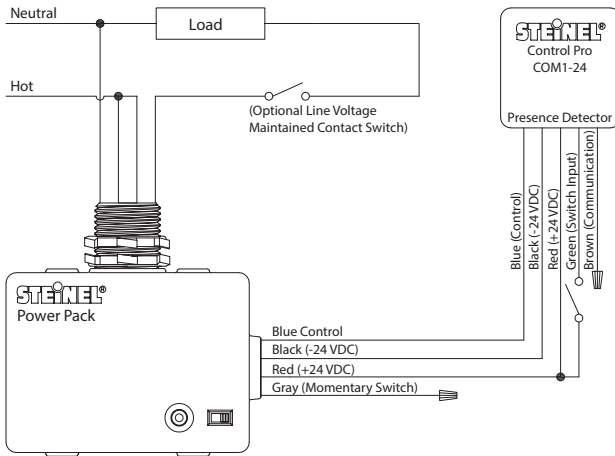

Settings

- 1 - Light level setting
- 2 - Occupancy time delay setting
- 3 - Ultrasonic reach setting
- 4 - Sensor DIP switch settings
- 5 - Trigger mode options

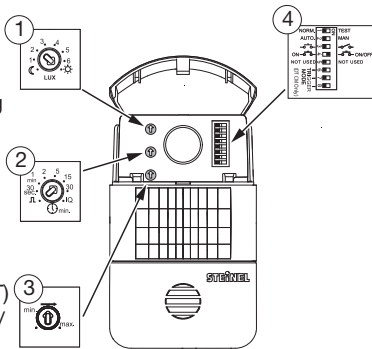

- DIP 1 - Normal mode / Test mode (NORM / TEST)
- DIP 2 - Automatic mode (AUTO) / Manual ON mode (MAN)
- DIP 3 - Momentary / Maintained switch option
- DIP 4 - 'ON' only / 'ON' & 'OFF' manual switching
- DIP 5 - Not used
- DIP 6/7/8 - Trigger mode

Trigger Mode Options	Initial Occupancy	Maintain Occupancy	DIP 6	DIP 7	DIP 8
Option 1 (factory setting)	Both	Either	↓ OFF	↓ OFF	↓ OFF
Option 2	Both	Both	↓ OFF	↓ OFF	↑ ON
Option 3	PIR	Either	↓ OFF	↑ ON	↓ OFF
Option 4	US	Either	↓ OFF	↑ ON	↑ ON
Option 5	Either	Either	↑ ON	↓ OFF	↓ OFF
Option 6	US	US	↑ ON	↓ OFF	↑ ON
Option 7	PIR	PIR	↑ ON	↑ ON	↓ OFF
Option 8	Either	Both	↑ ON	↑ ON	↑ ON

The trigger mode enables the user to choose which sensing technologies should be used to initially turn the load on and which technologies are required to keep it on.

Mounting

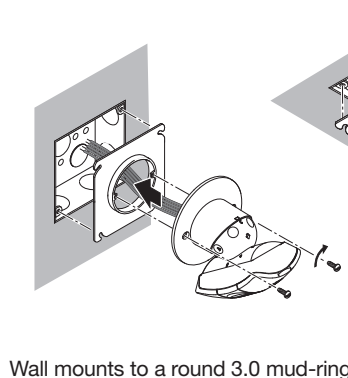
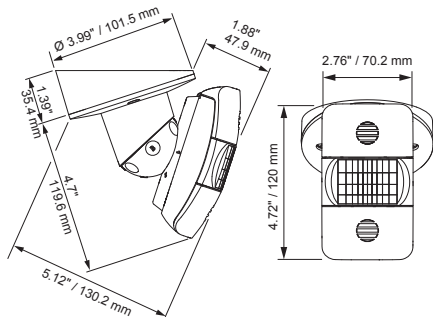

Wall mounts to a round 3.0 mud-ring

Ceiling mounts to a round 3.0 mud-ring using the ceiling mount adapter

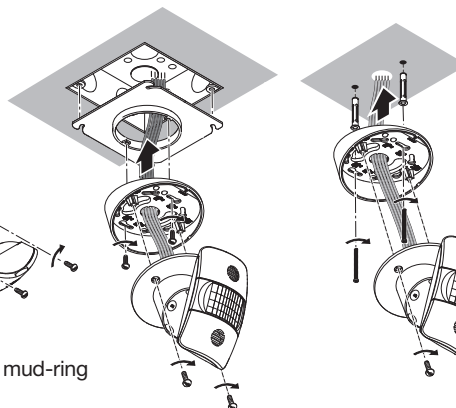

Can be mounted directly to the ceiling or wall using anchor bolts or can be mounted to the ceiling using the supplied 1/2" snap in chase nipple, washer and lock nut. When mounting to the ceiling, the ceiling mount adapter should be used.

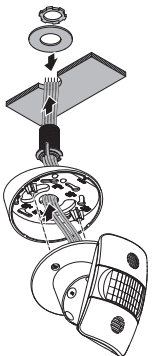

Coverage

Shown coverage diagram at 9 ft mounting height. Ultrasonic signal can be increased by hard surfaces and decreased by soft surfaces.

- PIR Tangential Detection
- - - PIR Radial Detection
- PIR Presence Detection
- Wall

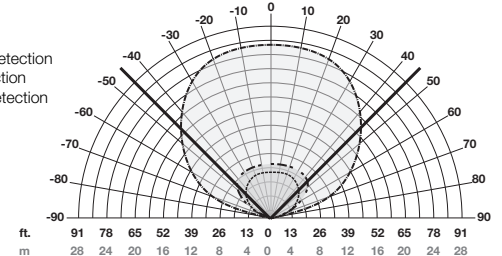

- US Radial Detection
- - - US Tangential Detection
- US Presence Detection

