

US Quattro COM1-24

Presence Detector



The US Quattro COM1-24 is a low voltage Ultrasonic Technology Presence Detector (40 kHz) that utilizes STEINEL's state of the art ultrasonic signal processing to providing superior stable volumetric omnidirectional detection. Ultrasonic is used for best practice in design and retrofit applications where the sensor will not have a clear line of sight view of the occupants in the desired coverage area. Operational choices of manual on or auto on with either momentary or maintained switch options. The force off light level feature provides the option to turn lights off when sufficient daylight is present for additional energy savings. The convenient "COM-Link" feature enables multiple sensors to link together via the communication link for peer to peer grouping achieving expanded detection zones with convenient control set up functions set at only one primary sensor for the entire group. Mounting options provide for 4" Square box, 4" Octagon box, Round 3.0 Mud-Ring or directly to the ceiling with quick mount spring tabs. The available service and user wireless remotes provide simplified commissioning and occupant convenience.

The Control PRO group of sensors are available in multiple technologies for the control of heating, ventilation and air conditioning as well as lighting (as in the COM2-24 versions) and optional 1-10 volt dimming and daylighting options (in the DIM-24 versions).

Applications

Typical applications are for large open areas with cubicals, work stations, conference rooms, bathrooms, storage areas with racking or applications requiring a volumetric pattern of detection.

Project Name:

Location:



US Quattro COM1-24 Specifications

Item No.	64510 US Quattro COM1-24
Accessories	65300 RC 3 service remote 65320 RC 4 user remote 65330 WGC wire guard cage
Voltage	18 - 24 VDC/VAC (30 mA) 50/60 Hz
Load Rating	control output - 1 A @ 30 VAC/VDC
Sensing Technology	ultrasonic (40 kHz)
Time Delay Setting	control output 30 sec. - 30 min. pulse mode (approx. 2 sec. 'ON' 8 sec. 'OFF') IQ mode (automatic adjustment to the usage profile)
Light Level Setting	10 - 1000 lux / 1 - 100 fc
Environment	IP20 rated, 0°C to +40°C, 32°F to +104°F
Ultrasonic Detection Zones: (Coverage at 2.5 m / 9 ft)	presence: max. 6 x 6 m (36 sq.m.) max. 20 x 20 ft (400 sq.ft.) min. 2 x 2 (4 sq.m.) min. 6.5 x 6.5 ft (42.25 sq.ft.) radial / tangential: max. of up to 10 x 10 m (100 sq.m.) radial / tangential: max. of up to 32 x 32 ft (1000 sq.ft.)
Dimensions	4.72 x 4.72 x 2.68 in, 120 x 120 x 68 mm (LxWxD)
Warranty	5 years
Certifications	C-UL-US Listed, RoHS compliant, UL 2043 Plenum Rated, CA Energy Code compliant

Key Features:

- Low voltage (18-24 VDC/VAC) sensor for use with a power pack or building automation system
- Omnidirectional ultrasonic (40 kHz) presence detection
- Service and user wireless remotes available
- Manual ON mode (MAN) / Automatic mode (AUTO)
- Momentary / Maintained switch option
- 'ON' only / 'ON' & 'OFF' manual switching
- Light level feature turns lights off when sufficient daylight is present
- Mounts to a 4" square box, 4" octagon box, round 3.0 mud-ring or directly to the ceiling with quick mount spring tabs
- IQ Mode dynamically adjusts the 'ON' time delay by learning individual room occupancy



Ultrasonic



20 x 20 Ft Presence
32 x 32 Ft Max



1 - 100 fc



18-24 VDC/VAC



30 Sec - 30 Min

US Quattro COM1-24

Presence Detector

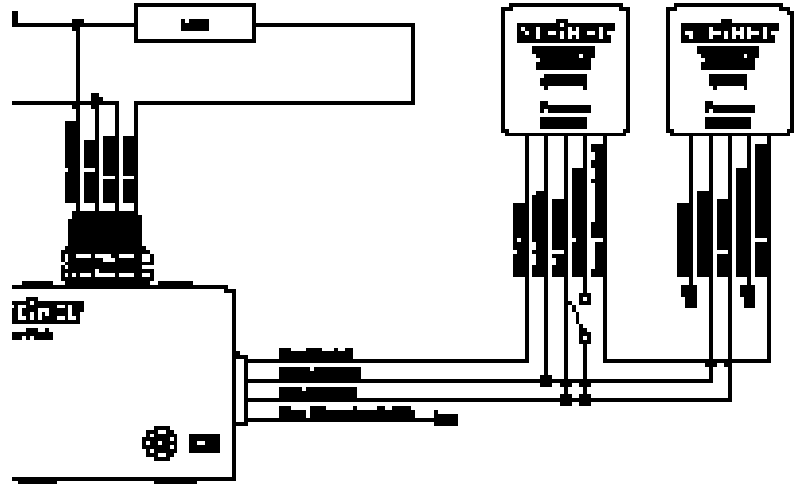
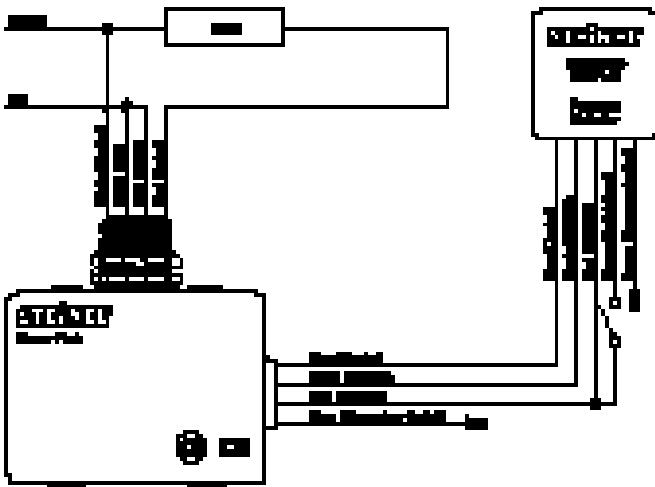

Setting

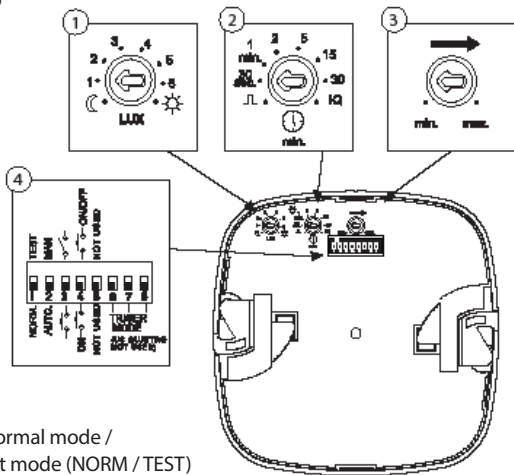

- DIP 1 - Normal mode / Test mode (NORM / TEST)
- DIP 2 - Manual ON mode (MAN) / Automatic mode (AUTO)
- DIP 3 - Momentary / Maintained switch option
- DIP 4 - 'ON' only / 'ON' & 'OFF' manual switching
- DIP 5 / 6 / 7 / 8 - Not used

- 1 - Light level setting
- 2 - Occupancy time delay setting
- 3 - Reach setting
- 4 - Sensor DIP switch settings

Coverage

Shown coverage diagram at 9 ft mounting height. Ultrasonic signal can be increased by hard surfaces and decreased by soft surfaces.

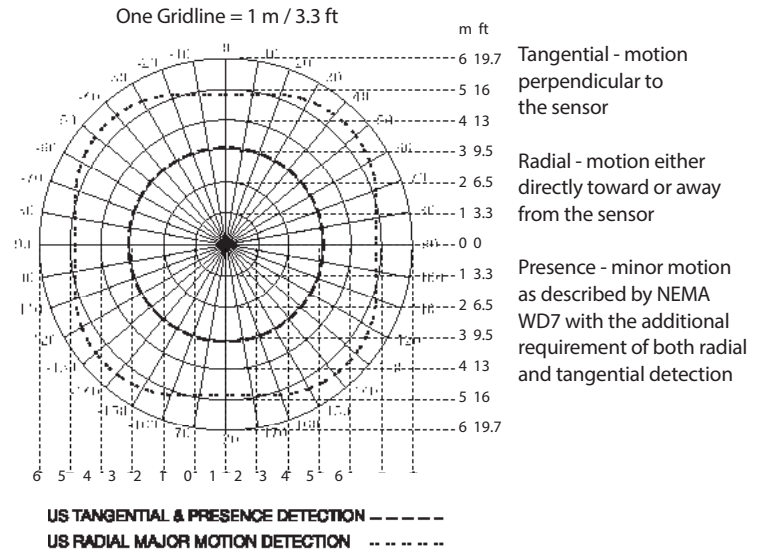

Mounting

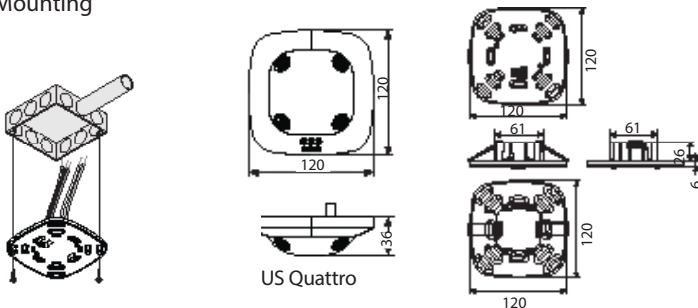

Mounts to a 4" Square box, 4" Octagon box or Round 3.0 Mud-Ring

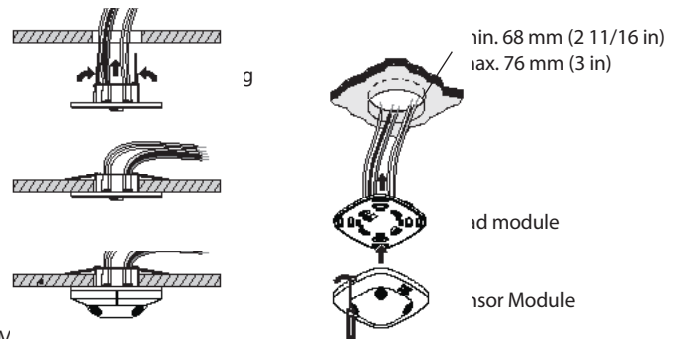

M with quick mount spring tabs